

# THE SEALPRO INSTALLER

## PRODUCT FOCUS

### Heavy Glass Option for Signature By-pass

In response to the increasing demand for heavy glass enclosures, Southeastern Aluminum has recently added a  $\frac{3}{8}$  inch glass option to our Signature by-pass enclosure system. The heavy glass option includes hanger brackets fastened through-the-glass for safety and a dual durometer center guide with a rigid frame and soft guide fins for smooth, quiet operation. The sill track has been redesigned with a rounded lip for better water drainage back into the shower, as well as for the prevention of pooling and splash out. The  $\frac{3}{8}$  inch Signature by-pass option is available in finishes of silver, gold, brushed nickel or white, either KD or glazed. Stock glazed units include a 60" tub, 48" shower and 60" shower in clear glass.



## PRODUCT NEWS

### CrystalLine Panel Kits

Southeastern Aluminum has added two new panel kits to accommodate tall-height units. The PKX1 (48" x 75" ht.) is for in-line level applications and the PKX5 (24" x 30" x 24" x 75" ht.) is for neo-angle level applications.

### CrystalLine Door Kits

Two new door kits are now available – DKX300 (30" x 75" ht.) in clear and DKDX300 (30" x 84" ht.) KD.

### Brushed Nickel

Brushed Nickel is now available on our regular CrystalLine frameless hinge door with knock-on handle.

### CrystalLine Stock Lengths

84" stock lengths have been added for all CrystalLine hinge door verticals to accommodate taller height units. Included are SEJ 101, SEJ 102, SEJ 104, SEJ 105 and SEJ 109.

148" stock lengths are now available for the

## Marketing Tools

Southeastern Aluminum Products, Inc. has unveiled a new web page on the World Wide Web. Now you can log onto the Internet and get detailed information about our products, installation instructions, and technical tips as well as submit orders for stock items and requests for additional information. We will be updating our web page on a monthly basis with information about our ever-changing product line along with helpful installation and maintenance tips.

[www.southeasternaluminum.com](http://www.southeasternaluminum.com) is not only a great way to access Southeastern Aluminum but is an excellent new way to market bath enclosures and mirror closet doors. Dealers who have Internet access can now use the Southeastern Aluminum web page to give their customers a closer look at all of the available options.

If you would like to submit photographs of custom shower applications for display on the web page, or if you have your own web page and would like to have a direct link to Southeastern Aluminum, please contact our Web Administrator.

For additional information, please contact:  
Monica Haymon  
Southeastern Aluminum Products, Inc.  
Post Office Box 6427  
Jacksonville, FL 32236  
(904) 781-8200  
[seap@southeasternaluminum.com](mailto:seap@southeasternaluminum.com)

## Technology Talk

It may be difficult to see how technology can affect a shower door but, at Southeastern Aluminum, technology projects are infused into many parts of the underlying structure of our product.

Forefront on our project list is the new Product Configuration Software. This software will replace CrystalSoft. But take this statement with a grain of salt. Our new Frontier Power Bids Plus software is Windows based and it will configure all of the different shower enclosure product lines manufactured by Southeastern Aluminum. It will give you a cut sheet, a price with your personal multiplier factored in, and will also allow you to print an invoice for your customer with the desired mark-up. The circa 1994 CrystalSoft software does not compare with our *new* product configuration software. This project has been underway for just over a year. We are looking forward to Beta testing the software during the end of July and early August. After we are confident that the 'bugs' have been worked out, it will be ready to release to our customers. We believe it is well worth the wait, please be patient.

The Technology Department is also completing a major software upgrade to our Accounting and ERP (Enterprise Resource Planning) software. With the speed of the new system the customer service department will be able to better serve our customers.

In addition to the various projects in progress, we have transitioned to an in-house server for hosting our web site and e-mail. Please talk to your customer service representative if you are not already utilizing our available technology. We are happy to receive orders in the form most convenient for you.

## Sales Department

We have recently added two new sales representatives to our outside sales group. John David Stien is based in Indianapolis, IN and will be covering Ohio, Kentucky, Indiana, Michigan, Wisconsin and Central and Northern Illinois. Brandon Roe is based in Raleigh, NC and will be covering South Carolina (excluding Greenville, Anderson and Aiken), North Carolina as well as Central and Southern Virginia.

Both Brandon and John David have completed their initial factory training and are now in field training. We welcome them to Southeastern Aluminum.



From Right: Suzanne Reott, Technology Manager; Raye Thomas, Technology Assistant.

## Customer Service

**New CSR:** Many of you have already spoken with Auriela Nuxoll. She is out of training and ready to provide you with quality customer service. We would like to welcome her to our team.

**Behind the Scenes:** We have a new addition 'Behind the Scenes'. Karen Strader is our new Customer Service Assistant. She comes to us from the receptionist position in our main office. We also welcome Karen aboard.

**New Fax Machine:** We have a new fax machine up and running. The fax number has not changed, but there should be no further problems with our fax line being busy. We apologize for any inconvenience in the past.

**Complaints:** When filing a complaint on a particular unit or any part of a unit it is very important that we have access to the information on the white label of the package. We do extensive research on complaints that will sometimes fuel product changes, extrusion specification changes, etc. But, without the label information, investigation is very difficult. Please retain the white label(s) on your packaging so that customer service can get the work order number, date and part number. Your assistance with this will allow us to better serve you.

**Lunch Closing:** As most of you are aware, we have been closing for lunch from 12 o'clock to 1 o'clock since March 5, 2001. If you have any comments, please do not hesitate to let a representative know.

# PRODUCT DEVELOPMENT

## CrystalLine Hinge System Adjustable Post Assembly

To facilitate the assembly of the SEJ 117 and SEJ 118 adjustable post assembly, drill guide grooves have been added to both of these extrusions. These grooves will make it easier to drill screw holes for fastening the parts together. Also, units requiring an adjustable post assembly will be shipped with the SEJ 118 pre-drilled.

## CrystalLine Hinge System Filler Piece

The SEJ 140 filler piece will be offered to correct out-of-level conditions when used with the SEJ 119 threshold. The SEJ 140 will be offered in full-length extrusions that can be cut to size. The extrusions will also be offered pre-cut to a  $\frac{5}{8}$  inch slope in a 60 inch length.

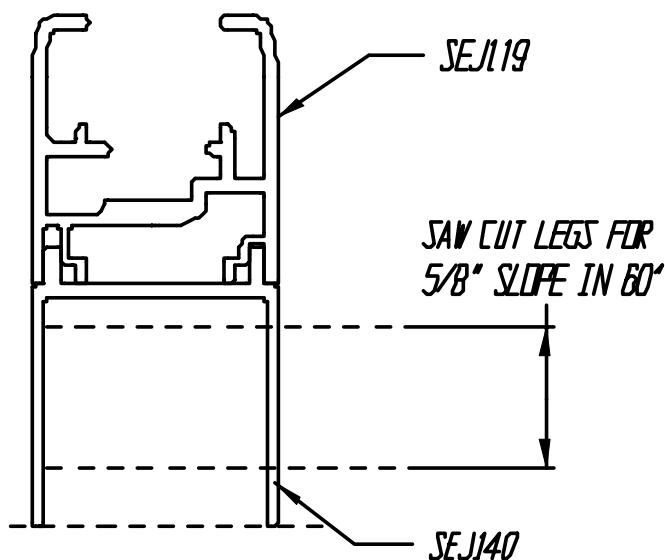

## CrystalLine Frameless Door Handles

For many months CrystalLine frameless handles and holders have been equipped with machined, one-piece magnetic strike plates. The new plates are held in place using a double staking procedure followed by a quadruple staking procedure. This improved process will insure that the new strike plates are held firmly in place.

## CrystalLine Frameless Hinge Glazing Bead

The  $\frac{1}{4}$  inch glass bead for the CrystalLine frameless hinge door now has a thicker profile. The bead wall thickness has been increased to compensate for the fact that  $\frac{1}{4}$  inch glass is now actually 6mm glass, which is .014 inches thinner than  $\frac{1}{4}$  inch glass.

## CrystalLine/Classic By-Pass Filler Piece

A new filler piece extrusion, SEJ 87, will be available to correct out-of-level conditions for the SEJ 31 (CrystalLine) and SEJ 68 (Classic) by-pass door sill tracks. The same filler piece will correct out-of-plumb conditions for the SEJ 34 (CrystalLine) and SEJ 86 (Classic) wall jambs.

The SEJ 87 will be offered in full-length extrusions that can be cut to size. The extrusion will also be offered pre-cut to a  $\frac{5}{8}$  inch slope in a  $68 \frac{9}{16}$  inch length.

## Signature By-Pass Dual Durometer Sill Guides

Signature by-pass doors now have a new, extruded, dual durometer sill guide. The new, dual durometer guide will offer a smoother, quieter door operation. At the same time the Signature threshold will be replaced with a "rounded lip" threshold similar to that used on the CrystalLine by-pass doors. The rounded lip greatly improves water run-off.

## New Adhesive for the CrystalLine Frameless Drip

A new double-sided adhesive (VHB) tape has been in use on the CrystalLine frameless drip since March, 2001. This tape has been tested and shows a 75% greater pull test strength over the tape previously used.

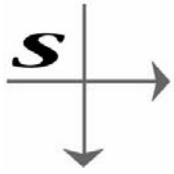

*Southeastern Aluminum Products, Inc.*

## THE SEALPRO INSTALLER

A Newsletter For The Valued Customers Of  
Southeastern Aluminum Products, Inc.  
P.O. Box 6427  
Jacksonville, Florida 32236

Check us out on the World Wide Web...

[www.southeasternaluminum.com](http://www.southeasternaluminum.com)

*Quality Products You Expect...  
Personal Service You Deserve*

### TECHNICAL TIP

#### INSTALLATION OF CRYSTALLINE ADJUSTABLE POST (SEJ 117/118)

For an easier installation of the adjustable post assembly on the CrystalLine Hinge system, try the following:

**STEP #1:**

Establish the proper angle between the SEJ 117  
& SEJ 118.

**STEP #2:**

Clamp part at the established  
angle, top and bottom.

**STEP #3:**

Install the tek screws, through  
the pre-punched holes in the  
SEJ 118, into the SEJ 117.

